

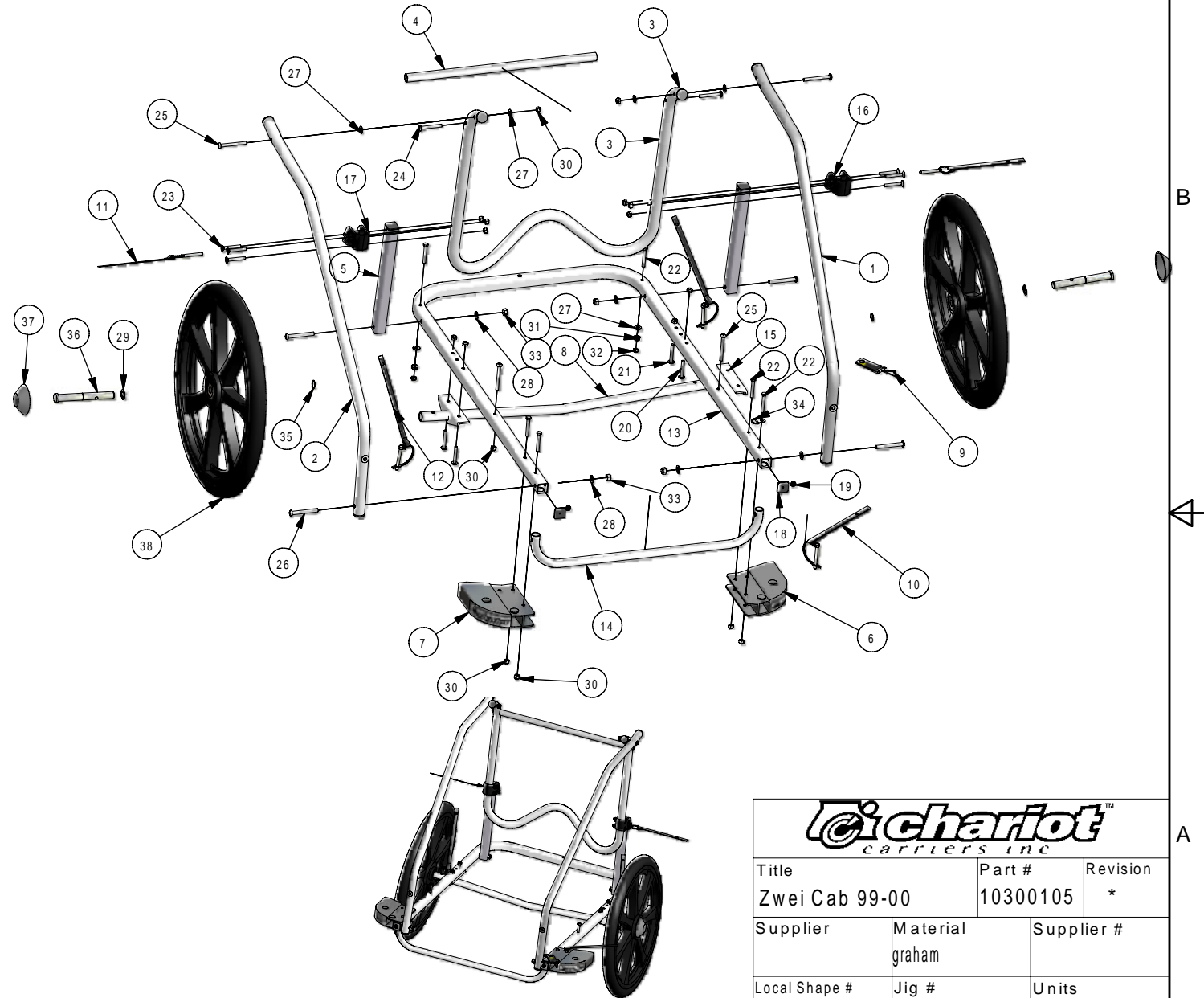

Parts List			
IT	QT	ITEM #	DESCRIPTION
1	1	40100105	Upper Frame L
2	1	40100106	Upper Frame R
3	1	40100403	Back Frame
4	1	40100601	Seat Frame
5	2	40100712	Back Tube SQ
6	1	40101502	Left Wing-Small-(Chariot)-(Black)
7	1	40101503	Right Wing-Small-(Chariot)-(Black)
8	1	40101723	Hollow Axle - Welded
9	1	40202003	Strap - Hitch Arm Secondary Strap
10	1	40202006	Strap - Hitch Arm Snap Pin Strap
11	2	40202007	Securing Pin, short
12	2	40202009	Strap - looper
13	1	41100202	Lower Frame Cab
14	1	41100454	Front Frame - U
15	1	41101204	Bracket Wheel - CDD/CAB L
16	1	41101281	Back Bracket Set - L (Grey)
17	1	41101282	Back Bracket Set - R (Grey)
18	2	41102124	Cut - End Cap - 1" SQ 0.058
19	2	50100406	Stud Snap - 5/8 in
20	2	50100510	Bolt 1/4-20x1 5/8" TR
21	2	50100512	Bolt 1/4-20x1 3/4" TR
22	6	50100514	Bolt 1/4-20x1 3/4" HX
23	6	50100516	Bolt 1/4-20x1 3/4" FL
24	2	50100518	Bolt 1/4-20x2" TR
25	4	50100524	Bolt 1/4-20x2 1/2" TR
26	4	50100550	Bolt 5/16-18x2 1/2" TR
27	6	50100614	Washer 1/4" SAE
28	6	50100616	Washer 5/16" SAE
29	2	50100620	Wave Washer - 5/8" ID
30	18	50100705	Nut lock 1/4"
31	2	50100706	Nut - Flange 1/4"
32	2	50100708	Nut - Jam 1/4"
33	4	50100710	Nut Lock 5/16
34	1	50100901	D Ring & Clip
35	2	50100902	External Retaining Ring - 5/8" (Zinc Plated)
36	2	50101303	Clevis Axle
37	2	50101413	Wheel End Cap for GH-206S/206P
38	2	50101712	Plastic Wheel 20"



		
Title	Part #	Revision
Zwei Cab 99-00	10300105	*
Supplier	Material	Supplier #
	graham	
Local Shape #	Jig #	Units
		mm (in)
Drawn By	Date	Predecessor's #
graham	9/18/2003	